



PIN type



SMA type

FEATURES

1. Compact size (Approx. 85% less volume compared to previous product.*)
PIN type size: L 15.9 × W 15.9 × H 11.2 mm L .626 × W .626 × H .441 inch
2. Excellent high frequency characteristics (to 8, 18, 26.5GHz, 50Ω)
3. Terminal shape options available (PIN and SMA)**
4. Contact arrangement: SPDT
5. Failsafe type and latching type (2-coil latching type) that reduces operating power are now available.

*Compared to previous product (RD coaxial switch) and PIN type RV coaxial switch.

**For SMP connector type, please contact us.

TYPICAL APPLICATIONS

- Compact wireless devices
- Compact measuring instrument
- All types of inspection equipment
- Digital broadcasting
 - Broadcasting relay station
 - Broadcasting equipment
- Mobile communication
 - Cellular phone base station

- 1) If you consider using applications requiring frequent switching or high number of operations, please contact us.
- 2) If you consider using applications with low level load, please contact us.

HIGH FREQUENCY CHARACTERISTICS (Impedance 50Ω, Initial)

1. PIN type

| Frequency | to 4 GHz | 4 to 8 GHz | 8 to 12.4 GHz* | 12.4 to 18 GHz* |
|---------------------------|----------|------------|----------------|-----------------|
| V.S.W.R. (max.) | 1.3 | 1.4 | 1.5 | 1.7 |
| Insertion loss (dB. max.) | 0.3 | 0.4 | 0.5 | 0.7 |
| Isolation (dB. min.) | 70 | 60 | 50 | 40 |

Note: *8 to 18GHz characteristics can be applied 18GHz type only.

2. SMA type

| Frequency | to 8 GHz | 8 to 12.4 GHz* | 12.4 to 18 GHz* | 18 to 26.5 GHz** |
|---------------------------|----------|----------------|-----------------|------------------|
| V.S.W.R. (max.) | 1.35 | 1.6 | 1.7 | 1.8 |
| Insertion loss (dB. max.) | 0.3 | 0.5 | 0.7 | 0.8 |
| Isolation (dB. min.) | 70 | 60 | 60 | 50 |

Note: *8 to 18GHz characteristics can be applied 18GHz type and 26.5GHz type only.

**18 to 26.5GHz characteristics can be applied 26.5GHz type only.

ORDERING INFORMATION

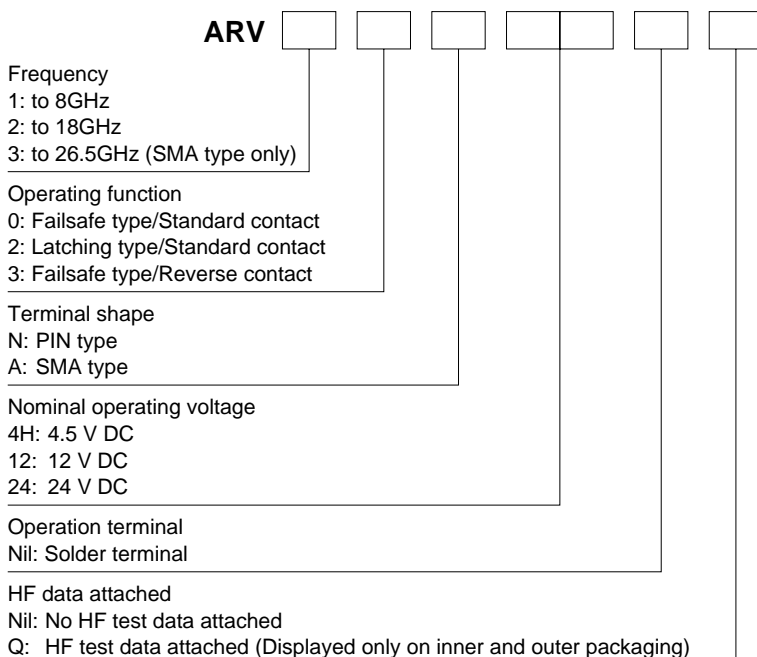

*Please inquire regarding use with nominal operating voltage of 28 V DC.

RV (ARV)

TYPES

SPDT

| Operating function | Contact terminal shape | Nominal operating voltage | to 8 GHz type | | to 18 GHz type | | to 26.5 GHz type | |
|------------------------------------|------------------------|---------------------------|--------------------------|-----------------------|--------------------------|-----------------------|--------------------------|-----------------------|
| | | | No HF datasheet attached | HF datasheet attached | No HF datasheet attached | HF datasheet attached | No HF datasheet attached | HF datasheet attached |
| Failsafe type/ Standard contact | PIN type | 4.5 V DC | ARV10N4H | ARV10N4HQ | ARV20N4H | ARV20N4HQ | – | – |
| | | 12 V DC | ARV10N12 | ARV10N12Q | ARV20N12 | ARV20N12Q | – | – |
| | | 24 V DC | ARV10N24 | ARV10N24Q | ARV20N24 | ARV20N24Q | – | – |
| | SMA type | 4.5 V DC | ARV10A4H | ARV10A4HQ | ARV20A4H | ARV20A4HQ | ARV30A4H | ARV30A4HQ |
| | | 12 V DC | ARV10A12 | ARV10A12Q | ARV20A12 | ARV20A12Q | ARV30A12 | ARV30A12Q |
| | | 24 V DC | ARV10A24 | ARV10A24Q | ARV20A24 | ARV20A24Q | ARV30A24 | ARV30A24Q |
| Latching type/ Standard contact | PIN type | 4.5 V DC | ARV12N4H | ARV12N4HQ | ARV22N4H | ARV22N4HQ | – | – |
| | | 12 V DC | ARV12N12 | ARV12N12Q | ARV22N12 | ARV22N12Q | – | – |
| | | 24 V DC | ARV12N24 | ARV12N24Q | ARV22N24 | ARV22N24Q | – | – |
| | SMA type | 4.5 V DC | ARV12A4H | ARV12A4HQ | ARV22A4H | ARV22A4HQ | ARV32A4H | ARV32A4HQ |
| | | 12 V DC | ARV12A12 | ARV12A12Q | ARV22A12 | ARV22A12Q | ARV32A12 | ARV32A12Q |
| | | 24 V DC | ARV12A24 | ARV12A24Q | ARV22A24 | ARV22A24Q | ARV32A24 | ARV32A24Q |
| Failsafe type/ Reverse contact | PIN type | 4.5 V DC | ARV13N4H | ARV13N4HQ | ARV23N4H | ARV23N4HQ | – | – |
| | | 12 V DC | ARV13N12 | ARV13N12Q | ARV23N12 | ARV23N12Q | – | – |
| | | 24 V DC | ARV13N24 | ARV13N24Q | ARV23N24 | ARV23N24Q | – | – |
| | SMA type | 4.5 V DC | ARV13A4H | ARV13A4HQ | ARV23A4H | ARV23A4HQ | ARV33A4H | ARV33A4HQ |
| | | 12 V DC | ARV13A12 | ARV13A12Q | ARV23A12 | ARV23A12Q | ARV33A12 | ARV33A12Q |
| | | 24 V DC | ARV13A24 | ARV13A24Q | ARV23A24 | ARV23A24Q | ARV33A24 | ARV33A24Q |

Standard packing: Carton: 5 pcs. Case: 50 pcs.

RATING

1. Coil data

1) Failsafe type (Standard contact and Reverse contact)

| Nominal operating voltage | Pick-up voltage (at 20°C 68°F) | Drop-out voltage (at 20°C 68°F) | Nominal operating current [±10%] (at 20°C 68°F) | Coil resistance [±10%] (at 20°C 68°F) | Nominal operating power | Max. applied voltage (at 85°C 185°F) |
|---------------------------|---|---|---|---------------------------------------|-------------------------|--------------------------------------|
| 4.5 V DC | 75%V or less of nominal voltage*1 (Initial) | 10%V or more of nominal voltage*1 (Initial) | 155.7mA | 28.9Ω | 700mW | 110%V of nominal voltage |
| 12 V DC | | | 58.3mA | 205.7Ω | | |
| 24 V DC | | | 29.2mA | 822.9Ω | | |

2) Latching type (Standard contact)

| Nominal operating voltage | Set voltage (at 20°C 68°F) | Reset voltage (at 20°C 68°F) | Nominal operating current [±10%] (at 20°C 68°F) | Coil resistance [±10%] (at 20°C 68°F) | Nominal operating power | Max. applied voltage (at 85°C 185°F) |
|---------------------------|---|---|---|---------------------------------------|-------------------------|--------------------------------------|
| 4.5 V DC | 75%V or less of nominal voltage*1 (Initial) | 75%V or less of nominal voltage*1 (Initial) | 155.7mA | 28.9Ω | 700mW | 110%V of nominal voltage |
| 12 V DC | | | 58.3mA | 205.7Ω | | |
| 24 V DC | | | 29.2mA | 822.9Ω | | |

Notes: *1. Pulse drive (JIS C5442)

*2. Please inquire regarding use with nominal operating voltage of 28 V DC.

2. Specifications

| Characteristics | Item | Specifications | | | | | | | |
|--|---|--|--|-----------------|------------------|-----------------------------|-----------------|------------------|------------------|
| Contact | Arrangement | SPDT | | | | | | | |
| | Contact material | Gold plating | | | | | | | |
| | Contact resistance (Initial) | Max. 100mΩ (By voltage drop 10V AC 10mA) | | | | | | | |
| Rating | Contact input power (CW) | Max. 50W (at 3GHz) (V.S.W.R. 1.3 or less, no contact switching, ambient temperature 20°C 68°F)*1 | | | | | | | |
| | Nominal operating power | 700mW | | | | | | | |
| High frequency characteristics (Impedance 50Ω) | | PIN type*2 | | | | SMA type | | | |
| | Frequency | to 4 GHz | 4 to 8 GHz | 8 to 12.4 GHz*3 | 12.4 to 18 GHz*3 | to 8 GHz | 8 to 12.4 GHz*4 | 12.4 to 18 GHz*4 | 18 to 26.5 GHz*5 |
| | V.S.W.R. (max.) | 1.3 | 1.4 | 1.5 | 1.7 | 1.35 | 1.6 | 1.7 | 1.8 |
| | Insertion loss (dB, max.) | 0.3 | 0.4 | 0.5 | 0.7 | 0.3 | 0.5 | 0.7 | 0.8 |
| | Isolation (dB, min.) | 70 | 60 | 50 | 40 | 70 | 60 | 60 | 50 |
| Electrical characteristics | Insulation resistance (Initial) | Min. 1,000 MΩ (at 500 V DC) Measurement at same location as "breakdown voltage (Initial)" section. | | | | | | | |
| | Breakdown voltage (Initial) | Between open contacts | 500 Vrms for 1 min. (Detection current: 10mA) | | | | | | |
| | | Between contact and earth terminal | 500 Vrms for 1 min. (Detection current: 10mA) | | | | | | |
| | | Between contact and coil | 500 Vrms for 1 min. (Detection current: 10mA) | | | | | | |
| | | Between coil and earth terminal | 500 Vrms for 1 min. (Detection current: 10mA) | | | | | | |
| Time characteristics (at 20°C 68°F) | Operate time (Set time) | Max. 15ms (approx. 5ms) (Nominal operating voltage applied to the coil, excluding contact bounce time.) | | | | | | | |
| | Release time (Reset time) | Max. 15ms (approx. 5ms) (Nominal operating voltage applied to the coil, excluding contact bounce time.) (without diode, only for Release time) | | | | | | | |
| Mechanical characteristics | Shock resistance | Functional | Min. 500 m/s ² (Half-wave pulse of sine wave: 11ms, detection time: 10μs.) | | | | | | |
| | | Destructive | Min. 1,000 m/s ² (Half-wave pulse of sine wave: 6ms.) | | | | | | |
| | Vibration resistance | Functional | 10 to 55 Hz at double amplitude of 3mm (Detection time: 10μs.) | | | | | | |
| | | Destructive | 10 to 55 Hz at double amplitude of 5mm/15 to 2,000 Hz [W0 = 2.94 (m/s ²) ² /Hz] | | | | | | |
| Expected life | Mechanical | Min. 10 ⁶ (at 180 cpm) | | | | | | | |
| | Electrical (Hot switch) | Min. 3 × 10 ⁵ (1W High frequency load, at 3GHz, impedance 50Ω, V.S.W.R.; max. 1.3) (at 20 cpm) | | | | | | | |
| Conditions | Conditions for operation, transport and storage*6 | Ambient temperature: -55°C to +85°C -67°F to +185°F Humidity: 5 to 85% R.H. (Not freezing and condensing at low temperature) Air pressure: 86 to 106 kPa | | | | | | | |
| Unit weight | | PIN type: Approx. 12g .42oz | | | | SMA type: Approx. 20g .71oz | | | |

Notes: *1. Factors such as heating of the connected terminal influence the high frequency characteristics; therefore, please verify under actual conditions of use.

*2. Measuring method: After installing on dedicated inspection equipment

*3. 8 to 18GHz characteristics can be applied 18GHz type only.

*4. 8 to 18GHz characteristics can be applied 18GHz and 26.5GHz types only.

*5. 18 to 26.5GHz characteristics can be applied 26.5GHz type only.

*6. The upper operation ambient temperature limit is the maximum temperature that can satisfy the coil temperature rise value. Refer to "NOTES" on page 6.

RV (ARV)

REFERENCE DATA

1-(1). High frequency characteristics (PIN type)

Sample: ARV22N12

Measuring method: Measured with Agilent Technologies network analyzer (E8363B) after installing on dedicated inspection equipment.

• V.S.W.R.

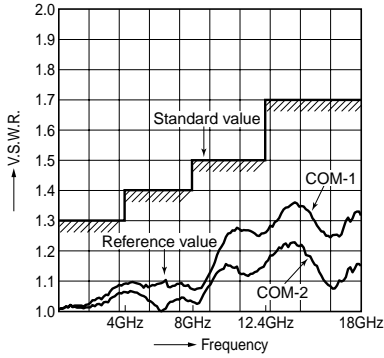

• Insertion loss

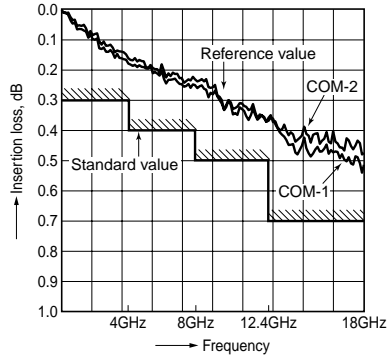

• Isolation

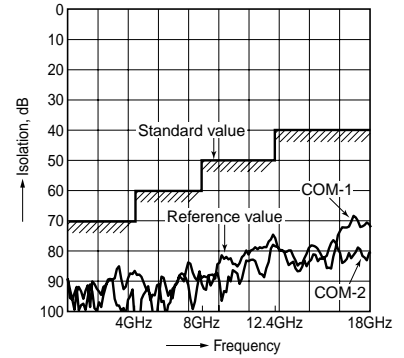

1-(2). High frequency characteristics (SMA type)

Sample: ARV32A12

Measuring method: Measured with Agilent Technologies network analyzer (E8363B).

• V.S.W.R.

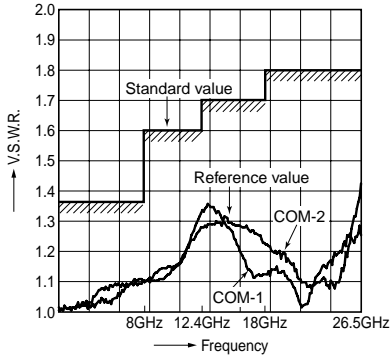

• Insertion loss

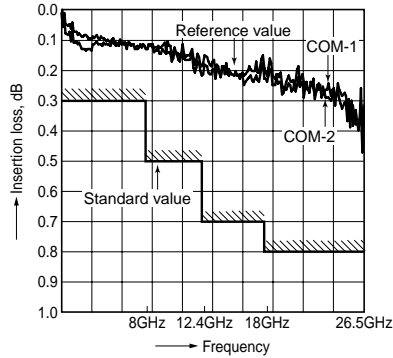

• Isolation

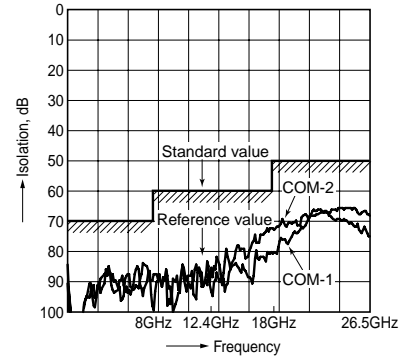

DIMENSIONS (mm inch) Interested in CAD data? You can obtain CAD data for all products with a **CAD Data** mark from [your local Panasonic Electric Works representative](#).

1. PIN type

CAD Data

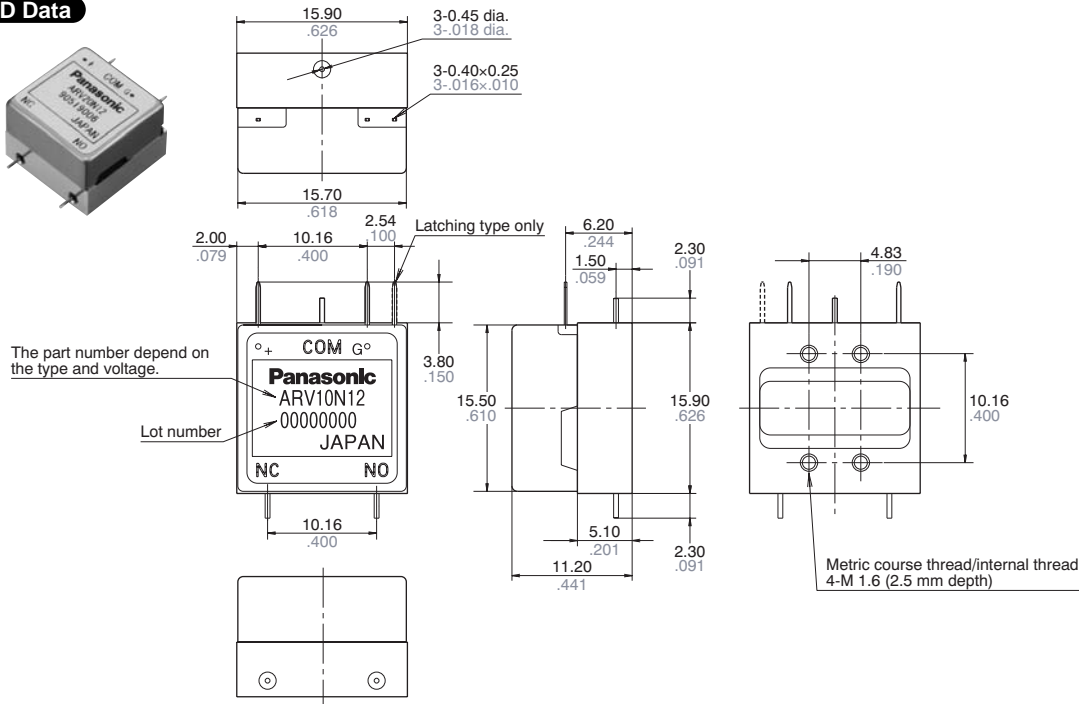

Tolerance: $\pm 0.3 \pm 0.12$

Schematic (Top view)

<Standard contact>
Failsafe type
(Deenergized condition)

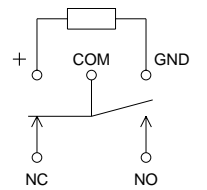

Latching type
(Reset condition)

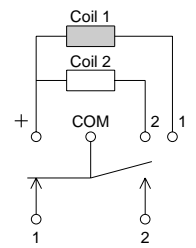

<Reverse contact>
Failsafe type
(Deenergized condition)

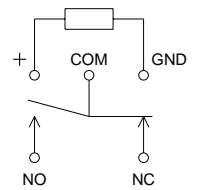

2. SMA type

CAD Data

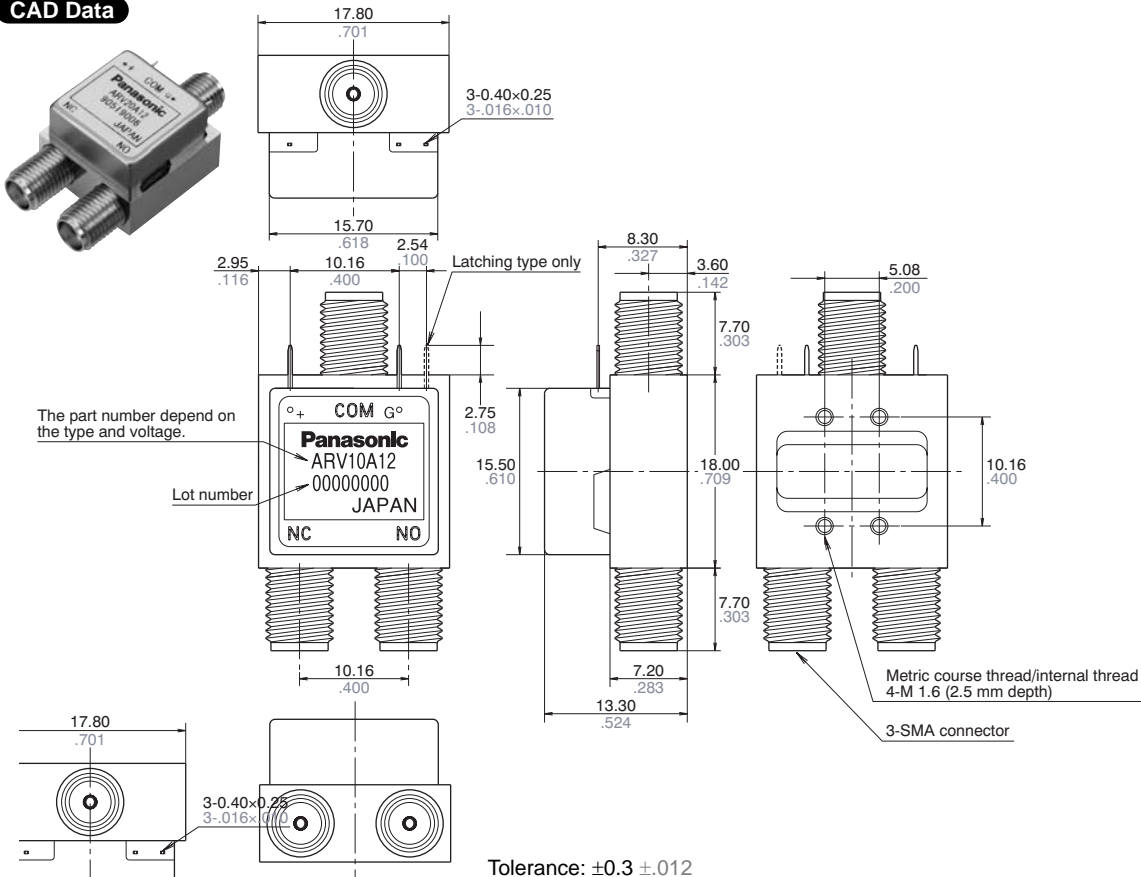

Tolerance: $\pm 0.3 \pm 0.12$

Schematic (Top view)

<Standard contact>
Failsafe type
(Deenergized condition)

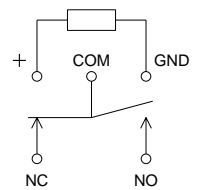

Latching type
(Reset condition)

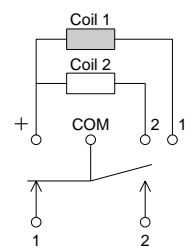

<Reverse contact>
Failsafe type
(Deenergized condition)

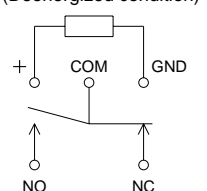

*For SMP connector type, please consult us.

RV (ARV)

NOTES

1. For general cautions for use, please refer to the “Cautions for Use” in the “Relay Technical Information”.

2. Coil operating power

Pure DC current should be applied to the coil. The wave form should be rectangular. If it includes ripple, the ripple factor should be less than 5%.

However, check it with the actual circuit since the characteristics may be slightly different. The nominal operating voltage should be applied to the coil for more than 50 ms to set/reset the latching type. Please use the latching type for circuits that are continually powered for long periods of time.

3. Coil connection

Since this product is polarized, please be aware of the plus/minus polarity of the coil.

4. Connection and washing conditions for coil and PIN type contact terminals

1) The connection of coil and PIN type contact terminals shall be done by soldering.

Soldering conditions

Max. 260°C 500°F (solder temp) within 10sec (soldering time)

Max. 350°C 662°F (solder temp) within 3sec (soldering time)

2) This product is not sealed type, therefore washing is not allowed.

5. Conditions for operation, transport and storage conditions

1) Temperature:

-55 to +85°C -67 to +185°F

2) Humidity: 5 to 85% RH

(Avoid freezing and condensation.)

The humidity range varies with the temperature. Use within the range indicated in the graph below.

3) Atmospheric pressure: 86 to 106 kPa

Temperature and humidity range for usage, transport, and storage:

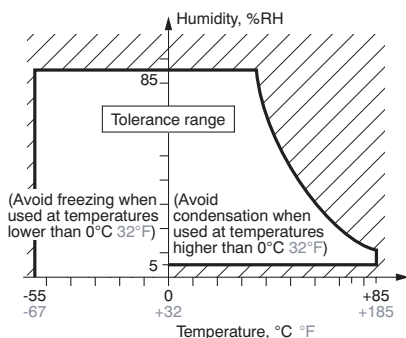

4) Condensation

Condensation forms when there is a sudden change in temperature under high temperature and high humidity conditions. Condensation will cause deterioration of coaxial switch insulation.

5) Freezing

Condensation or other moisture may freeze on coaxial switch when the temperature is lower than 0°C 32°F. This causes problems such as sticking of movable parts or operational time lags.

6) Low temperature, low humidity environments.

The plastic may become brittle if coaxial switch is exposed to a low temperature, low humidity environment for long periods of time.

6. Other handling precautions.

1) Coaxial switch's on/off service life is based on standard test conditions

(temperature: 15 to 35°C 59 to 95°F, humidity: 25 to 75%) specified in JIS C5442-1996. Life will depend on many factors of your system: coil drive circuit, type of load, switching intervals, switching phase, ambient conditions, to name a few.

2) Use coaxial switch within specifications such as coil rating, contact rating and on/off service life. If used beyond limits, coaxial switch may overheat, generate smoke or catch fire.

3) Be careful not to drop coaxial switch. If accidentally dropped, carefully check its appearance and characteristics before use.

4) Be careful to wire coaxial switch correctly. Otherwise, malfunction, overheat, fire or other trouble may occur.

5) The latching type product is shipped in the reset position. But jolts during transport or impacts during installation can move it to the set position. It is, therefore, advisable to build a circuit in which coaxial switch can be initialized (set and reset) just after turning on the power.

6) If coaxial switch stays on in a circuit for many months or years at a time without being activated, circuit design should be reviewed so that the coaxial switch can remain deenergized. A coil that receives current all the time heats, which degrades insulation earlier than expected. A latching type is recommended for such circuits.

7) For SMA connectors (SMA type only), we recommend a torque of 0.90±0.1 N·m for installation, which falls within the prescribed torque of MIL-C-39012.

Please be aware that conditions might be different depending on the connector materials and how it interacts with surrounding materials.

8) Please do not use silicon based substances such as silicon rubber, silicon oil, silicon coatings and silicon fillings, in the vicinity of the coaxial switch. Doing so may cause volatile silicon gas to form which may lead to contact failure due to the adherence of silicon on the contacts when they open and close in this atmosphere.

9) In order to ensure stable signal communication on contact, it is recommended that the monitoring of contact signal should be started from Min. 100 ms after coil rated voltage is applied.

For Cautions for Use, see [Relay Technical Information](#).