

Aluminum Capacitors Power Long Life 4-Terminal Snap-In

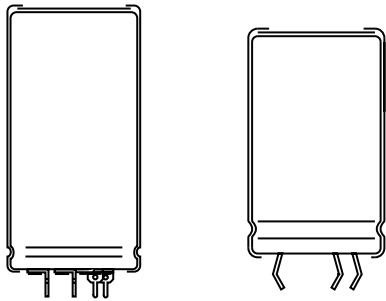
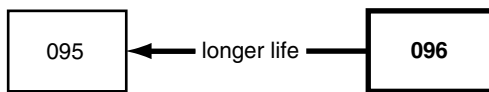

Fig.1 Component outlines



QUICK REFERENCE DATA	
DESCRIPTION	VALUE
Nominal case size (D x L in mm)	35 x 50 to 45 x 100
Rated capacitance range C_R	390 to 2700 μF
Tolerance on C_R	$\pm 20\%$
Rated voltage range, U_R	350 to 500 V
Category temperature range	- 40 to + 85 °C
Endurance test at 85 °C	2000 hours
Useful life at 85 °C	5000 hours
Useful life at 40 °C, 1.4 x I_R applied	200 000 hours
Shelf life at 0 V, 85 °C	1000 hours
Based on sectional specification	IEC 60384-4/EN130300
Climatic category IEC 60068	40/085/56

FEATURES

- Polarized aluminum electrolytic capacitors, non-solid electrolyte
- Large types, minimized dimensions, cylindrical aluminum case, insulated with a blue sleeve
- Pressure relief on the side of the aluminum case
- Very long useful life: 5000 hours at 85 °C
- Temperature range up to 85 °C
- Keyed polarity
- Low ESR, high ripple current capability

**RoHS
COMPLIANT**

APPLICATIONS

- Telecommunication and industrial systems
- Smoothing and filtering applications
- Switched mode power supplies
- Renewable energy power converters
- Energy storage in pulse systems
- For excellent mounting stability

MARKING

The capacitors are marked (where possible) with the following information:

- Rated capacitance (in μF)
- Tolerance code on rated capacitance, code letter in accordance with IEC 60062 (M for $\pm 20\%$)
- Rated voltage (in V)
- Date code (YYMM)
- Name of manufacturer
- Code for factory of origin
- ‘-’ sign to identify the negative terminal, visible from the top and side of the capacitor
- Code number
- Climatic category in accordance with IEC 60068

SELECTION CHART FOR C_R , U_R AND RELEVANT NOMINAL CASE SIZES (\varnothing D x L in mm)						
C_R (μF)	U_R (V)					
	350	385	400	420	450	500
390						35 x 60
470						35 x 70
560					35 x 60	35 x 70 40 x 60
680		35 x 50 40 x 50	35 x 60 40 x 50	35 x 60 40 x 50	35 x 70 40 x 50	35 x 80 40 x 70
820	35 x 50 40 x 40	35 x 60 40 x 50	35 x 60 40 x 50	35 x 70 40 x 60	35 x 80 40 x 60	35 x 100 40 x 80
1000	35 x 60 40 x 50	35 x 70 40 x 60	35 x 70 40 x 60 45 x 50	35 x 80 40 x 60	35 x 100 40 x 70 45 x 60	40 x 100 45 x 70

SELECTION CHART FOR C_R , U_R AND RELEVANT NOMINAL CASE SIZES ($\varnothing D \times L$ in mm)						
C_R (μF)	U_R (V)					
	350	385	400	420	450	500
1200	35 x 70 40 x 60	35 x 80 40 x 70	35 x 80 40 x 70 45 x 60	40 x 70	40 x 80 45 x 70	45 x 100
1500	35 x 80 40 x 70 45 x 60	40 x 80 45 x 60	35 x 100 40 x 80 45 x 70	40 x 100 45 x 70	40 x 100 45 x 80	45 x 100
1800	40 x 80 45 x 60	40 x 100 45 x 70	40 x 100 45 x 80	40 x 100 45 x 80	45 x 100	
2200	40 x 100 45 x 70	40 x 100	45 x 100	45 x 100		
2700	45 x 100	45 x 100	45 x 100			

DIMENSIONS in millimeters **AND AVAILABLE FORMS**

PRINTED WIRING

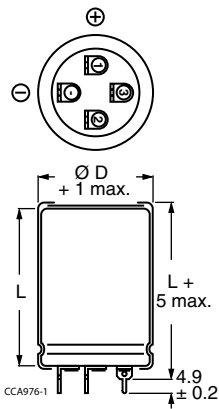

Case $\varnothing D = 35$ mm

Fig.2 Printed wiring pin version

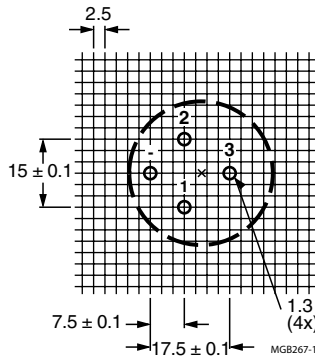

Case $\varnothing D = 35$ mm

Fig.3 Mounting hole diagram viewed from component side

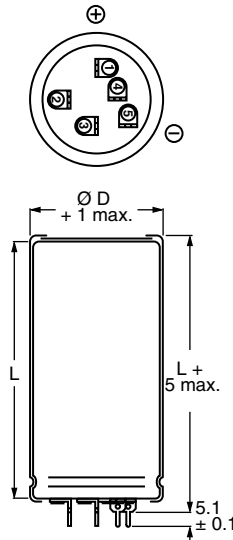

Case $\varnothing D = 40$ mm

Fig.4 Printed wiring pin version

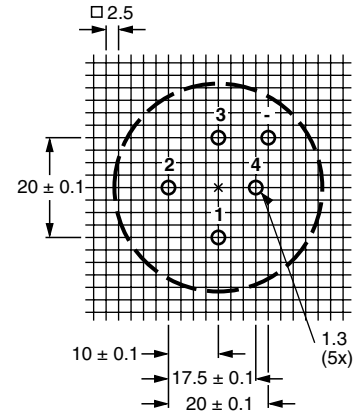

Case $\varnothing D = 40$ mm

Fig.5 Mounting hole diagram viewed from component side

FOUR TERMINAL SNAP-IN

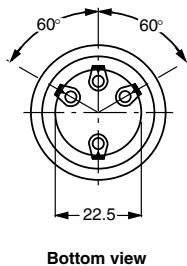

Bottom view

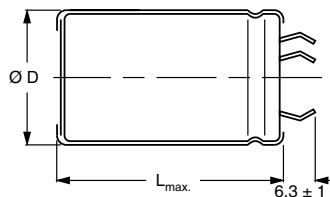
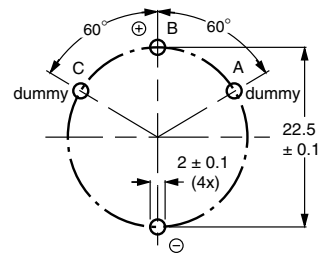

Fig. 6 4-Terminal snap-in



Dummy terminals (A and C) must be free from the electrical circuit

Fig. 7 Mounting hole diagram



Aluminum Capacitors
Power Long Life 4-Terminal Snap-In

Vishay BCcomponents

Table 1

DIMENSIONS in millimeters, MASS AND PACKAGING QUANTITIES						
NOMINAL CASE SIZE Ø D x L	Ø D _{max.}	4T-SI L _{max.}	PW L+5	MASS (g)	PACKAGING QUANTITIES (units per box)	CARDBOARD BOX DIMENSIONS L x W x H
35 x 50	36	52	55	72	50	390 x 198 x 60
35 x 60	36	62	65	91	50	390 x 198 x 70
35 x 70	36	72	75	103	50	390 x 198 x 80
35 x 80	36	82	85	115	25	TBD
35 x 100	36	102	105	151	25	TBD
40 x 40	41	42	45	70	50	440 x 223 x 60
40 x 50	41	52	55	94	50	440 x 223 x 70
40 x 60	41	62	65	118	25	230 x 230 x 80
40 x 70	41	72	75	134	25	230 x 230 x 90
40 x 80	41	82	85	150	25	230 x 230 x 100
40 x 100	41	102	105	176	25	230 x 230 x 120
45 x 40	46	42	-	88	36	TBD
45 x 50	46	52	-	119	36	TBD
45 x 60	46	62	-	150	36	TBD
45 x 70	46	72	-	170	36	TBD
45 x 80	46	82	-	190	36	TBD
45 x 100	46	102	-	250	36	TBD

ELECTRICAL DATA	
SYMBOL	DESCRIPTION
C _R	rated capacitance at 100 Hz
I _R	rated RMS ripple current at 100 Hz and 85 °C
I _{L5}	max. leakage current after 5 minutes at U _R
ESR	max. equivalent series resistance at 100 Hz
Z	max. impedance at 10 kHz

Note

1. Unless otherwise specified, all electrical values in Tables and apply at T_{amb} = 20 °C, P = 86 to 106 kPa, RH = 45 to 75 %.

ORDERING EXAMPLE

Electrolytic capacitor 096 series
820 µF/385 V;

Printed Wiring:

Ordering code: MAL209668821 E3

Former 12NC: 222209668821

4-Terminal Snap In:

Ordering code: MAL209618821 E3

Former 12NC: 222209618821

ELECTRICAL DATA AND ORDERING INFORMATION								
U _R (V)	C _R 100 Hz (µF)	NOMINAL CASE SIZE Ø D x L (mm)	I _R 100 Hz 85 °C (A)	I _{L(5)} 5 min (µA)	ESR 100 Hz (mΩ)	Z max. 10 kHz (mΩ)	CATALOG NUMBER MAL2096.....	
							4T-SI	PW
350	820	35 x 50	4.0	578	126	82	15821E3	65821E3
	820	40 x 40	3.8	578	134	90	25821E3	75821E3
	1000	35 x 60	4.7	704	104	67	15102E3	65102E3
	1000	40 x 50	4.8	704	108	72	25102E3	75102E3
	1200	35 x 70	5.3	844	87	57	15122E3	65122E3
	1200	40 x 60	5.4	844	90	59	25122E3	75122E3
	1500	35 x 80	6.0	1054	71	47	15152E3	65152E3
	1500	40 x 70	6.2	1054	73	49	25152E3	75152E3
	1500	45 x 60	6.3	1054	76	52	35152E3	-
	1800	40 x 80	6.9	1264	62	41	25182E3	75182E3
	1800	45 x 60	6.6	1264	68	48	35182E3	-
	2200	40 x 100	8.2	1544	51	34	25222E3	75222E3
	2200	45 x 70	7.4	1544	57	41	35222E3	-
	2700	45 x 100	9.2	1894	44	30	35272E3	-

**ELECTRICAL DATA AND ORDERING INFORMATION**

U _R (V)	C _R 100 Hz (μF)	NOMINAL CASE SIZE Ø D x L (mm)	I _R 100 Hz 85 °C (A)	I _{L(5)} 5 min (μA)	ESR 100 Hz (mΩ)	Z max. 10 kHz (mΩ)	CATALOG NUMBER MAL2096.....	
							4T-SI	PW
385	680	35 x 50	3.7	528	140	88	18681E3	68681E3
	680	40 x 50	4.2	528	140	87	28681E3	78681E3
	820	35 x 60	4.4	635	116	73	18821E3	68821E3
	820	40 x 50	4.5	635	120	76	28821E3	78821E3
	1000	35 x 70	5.0	774	96	60	18102E3	68102E3
	1000	40 x 60	5.1	774	99	63	28102E3	78102E3
	1200	35 x 80	5.5	928	81	51	18122E3	68122E3
	1200	40 x 70	5.7	928	83	53	28122E3	78122E3
	1500	40 x 80	6.5	1159	68	43	28152E3	78152E3
	1500	45 x 60	6.2	1159	74	50	38152E3	-
	1800	40 x 100	7.7	1390	56	36	28182E3	78182E3
	1800	45 x 70	7.0	1390	62	43	38182E3	-
	2200	40 x 100	8.2	1698	49	32	28222E3	78222E3
	2700	45 x 100	9.1	2083	43	29	38272E3	-
400	680	35 x 60	4.1	548	134	82	16681E3	66681E3
	680	40 x 50	4.2	548	138	85	26681E3	76681E3
	820	35 x 60	4.4	660	114	71	16821E3	66821E3
	820	40 x 50	4.5	660	119	75	26821E3	76821E3
	1000	35 x 70	5.0	804	94	59	16102E3	66102E3
	1000	40 x 60	5.1	804	97	62	26102E3	76102E3
	1000	45 x 50	5.1	804	103	67	36102E3	-
	1200	35 x 80	5.5	964	80	50	16122E3	66122E3
	1200	40 x 70	5.7	964	82	52	26122E3	76122E3
	1200	45 x 60	5.9	964	85	55	36122E3	-
	1500	35 x 100	7.1	1204	64	40	16152E3	66152E3
	1500	40 x 80	6.5	1204	67	43	26152E3	76152E3
	1500	45 x 70	6.6	1204	69	46	36152E3	-
	1800	40 x 100	7.7	1444	56	35	26182E3	76182E3
1800	45 x 80	7.3	1444	59	39	36182E3	-	
2200	45 x 100	8.6	1764	48	32	36222E3	-	
2700	45 x 100	9.1	2164	42	29	36272E3	-	
420	680	35 x 60	4.1	575	137	85	14681E3	64681E3
	680	40 x 50	4.2	575	141	89	24681E3	74681E3
	820	35 x 70	4.6	693	114	71	14821E3	64821E3
	820	40 x 60	4.7	693	117	74	24821E3	74821E3
	1000	35 x 80	5.1	844	95	59	14102E3	64102E3
	1000	40 x 60	5.1	844	100	64	24102E3	74102E3
	1200	40 x 70	5.7	1012	84	54	24122E3	74122E3
	1500	40 x 100	7.2	1264	66	42	24152E3	74152E3
	1500	45 x 70	6.6	1264	71	48	34152E3	-
	1800	40 x 100	7.6	1516	57	37	24182E3	74182E3
	1800	45 x 80	7.2	1516	60	40	34182E3	-
2200	45 x 100	8.5	1852	49	33	34222E3	-	



ELECTRICAL DATA AND ORDERING INFORMATION								
U _R (V)	C _R 100 Hz (µF)	NOMINAL CASE SIZE Ø D x L (mm)	I _R 100 Hz 85 °C (A)	I _{L(5)} 5 min (µA)	ESR 100 Hz (mΩ)	Z max. 10 kHz (mΩ)	CATALOG NUMBER MAL2096.....	
							4T-SI	PW
450	560	35 x 60	3.8	508	155	94	17561E3	67561E3
	680	35 x 70	4.2	616	129	78	17681E3	67681E3
	680	40 x 50	4.2	616	136	85	27681E3	77681E3
	820	35 x 80	4.8	742	108	66	17821E3	67821E3
	820	40 x 60	4.7	742	112	70	27821E3	77821E3
	1000	35 x 100	6.0	904	89	54	17102E3	67102E3
	1000	40 x 70	5.3	904	93	58	27102E3	77102E3
	1000	45 x 60	5.5	904	97	62	37102E3	-
	1200	40 x 80	6.0	1084	78	49	27122E3	77122E3
	1200	45 x 70	6.1	1084	81	52	37122E3	-
	1500	40 x 100	7.2	1354	63	39	27152E3	77152E3
	1500	45 x 80	6.8	1354	67	43	37152E3	-
	1800	45 x 100	8.0	1624	55	35	37182E3	-
500	390	35 x 60	2.9	394	475	421	19391E3	69391E3
	470	35 x 70	3.3	474	395	350	19471E3	69471E3
	560	35 x 70	3.6	564	333	296	19561E3	69561E3
	560	40 x 60	3.7	564	336	299	29561E3	79561E3
	680	35 x 80	4.1	684	275	245	19681E3	69681E3
	680	40 x 70	4.2	684	277	247	29681E3	79681E3
	820	35 x 100	5.1	824	229	203	19821E3	69821E3
	820	40 x 80	4.7	824	231	206	29821E3	79821E3
	1000	40 x 100	5.6	1004	189	169	29102E3	79102E3
	1000	45 x 70	5.3	1004	195	176	39102E3	-
	1200	45 x 100	6.4	1204	160	144	39122E3	-
	1500	45 x 100	7.0	1504	131	118	39152E3	-

ADDITIONAL ELECTRICAL DATA		
PARAMETER	CONDITIONS	VALUE
Voltage		
Surge voltage	≥ 350 V versions	U _s = 1.1 x U _R
Reverse voltage		U _{rev} ≤ 1
Current		
Leakage current	After 1 minute at U _R	I _{L1} ≤ 0.006 C _R x U _R + 4 µA
	After 5 minutes at U _R	I _{L5} ≤ 0.002 C _R x U _R + 4 µA
Inductance		
Equivalent series inductance (ESL)	All case sizes	ca. 20 nH



RIPPLE CURRENT AND USEFUL LIFE

CCC205-05

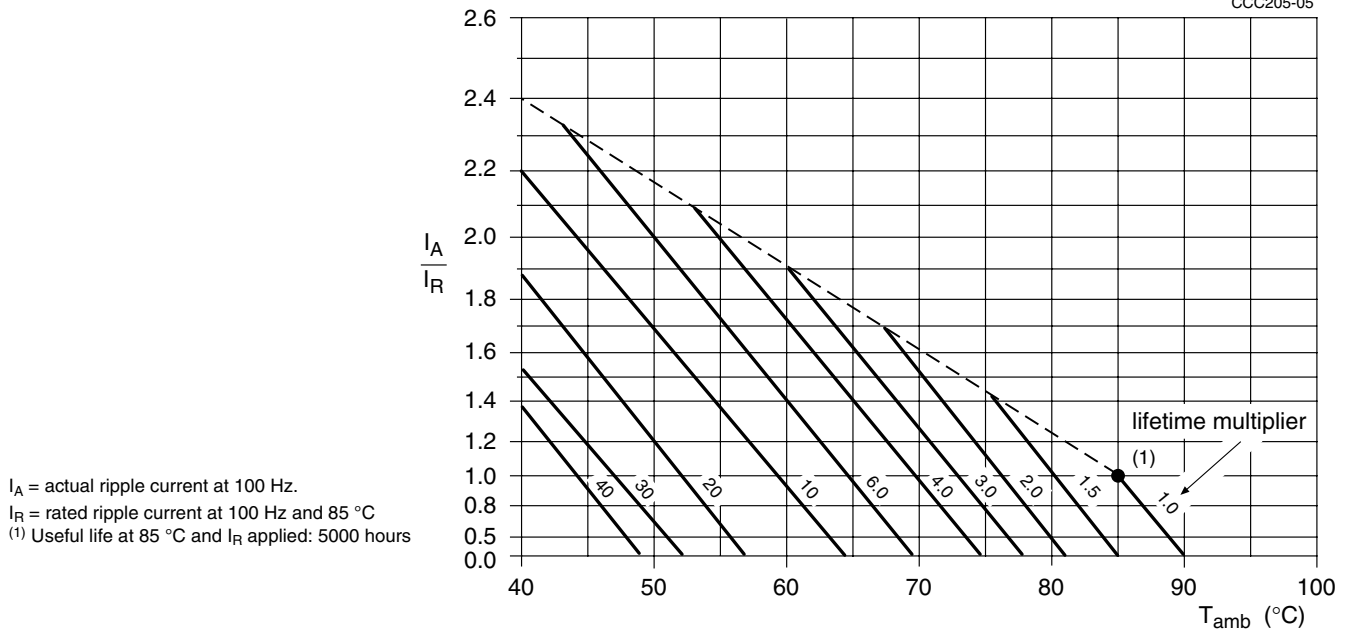

Fig.8 Multiplier of useful life as a function of ambient temperature and ripple current load

Table 2

MULTIPLIER OF RIPPLE CURRENT (I_R) AS A FUNCTION OF FREQUENCY	
FREQUENCY (Hz)	I_R MULTIPLIER
50	0.9
100	1.0
200	1.2
400	1.3
1000	1.4
10 000	1.5

Table 3

TEST PROCEDURES AND REQUIREMENTS			
TEST		PROCEDURE (quick reference)	REQUIREMENTS
NAME OF TEST	REFERENCE		
Endurance	IEC 60384-4/ EN130300 subclause 4.13	$T_{amb} = 85\text{ °C}$; U_R applied 2000 hours	$\Delta C/C: \pm 10\%$ ESR $\leq 1.3 \times$ spec. limit $Z \leq 2 \times$ spec. limit $I_{L5} \leq$ spec. limit
Useful life	CECC 30301 subclause 4.13	$T_{amb} = 85\text{ °C}$; U_R and I_R applied; 5000 hours	$\Delta C/C: \pm 30\%$ ESR $\leq 3 \times$ spec. limit $Z \leq 3 \times$ spec. limit $I_{L5} \leq$ spec. limit no short or open circuit, no visible damage total failure percentage: $\leq 3\%$
Shelf life	IEC 60384-4/ EN130300 subclause 4.17	$T_{amb} = 85\text{ °C}$; no voltage applied; 1000 hours After test: U_R to be applied for 30 minutes 24 to 48 hours before measurement	$\Delta C/C: \pm 10\%$ ESR $\leq 1.2 \times$ spec. limit $I_{L5} \leq 2 \times$ spec. limit



Disclaimer

All product specifications and data are subject to change without notice.

Vishay Intertechnology, Inc., its affiliates, agents, and employees, and all persons acting on its or their behalf (collectively, "Vishay"), disclaim any and all liability for any errors, inaccuracies or incompleteness contained herein or in any other disclosure relating to any product.

Vishay disclaims any and all liability arising out of the use or application of any product described herein or of any information provided herein to the maximum extent permitted by law. The product specifications do not expand or otherwise modify Vishay's terms and conditions of purchase, including but not limited to the warranty expressed therein, which apply to these products.

No license, express or implied, by estoppel or otherwise, to any intellectual property rights is granted by this document or by any conduct of Vishay.

The products shown herein are not designed for use in medical, life-saving, or life-sustaining applications unless otherwise expressly indicated. Customers using or selling Vishay products not expressly indicated for use in such applications do so entirely at their own risk and agree to fully indemnify Vishay for any damages arising or resulting from such use or sale. Please contact authorized Vishay personnel to obtain written terms and conditions regarding products designed for such applications.

Product names and markings noted herein may be trademarks of their respective owners.